



## Cluster Motor Ignition!

Cluster motor ignition is not magic, but it does present additional challenges. This section hopes to take some of the "magic" out of it and allow you to experience one successful launch after another!

### IGNITER

#### INSTALLATION:

Foremost is proper igniter installation. Refer to the figure below and make sure that you install your igniter such that the black tip of the igniter touches the fuel grain inside the motor nozzle, as shown. Hold in place with a small ball of recovery wadding or use a plug if provided.

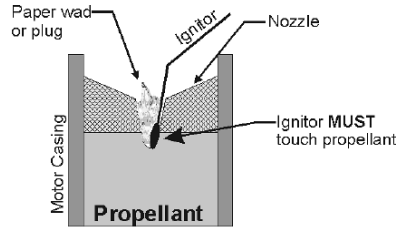

Cut-Away view showing igniter installation

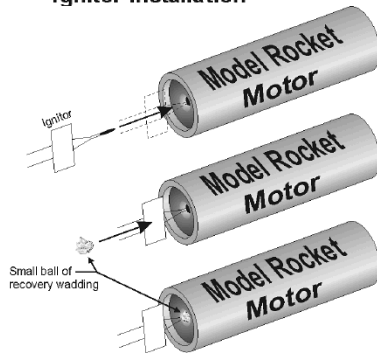

**IGNITER HOOKUP:** In order to successfully ignite a cluster of model rocket motors, you must have the igniters wired up in "Parallel", as shown in the figure below.

You can either twist the wires together, as shown, or you can use a "Clip-Whip" (multiple igniter clips wired together) to connect a pair of clips to each igniter. Just be sure they are hooked up in Parallel.

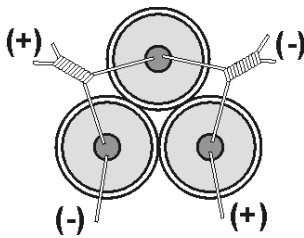

Below you can see an example of a simple launch controller with the igniters properly hooked up in parallel.

#### Simple Launch Controller

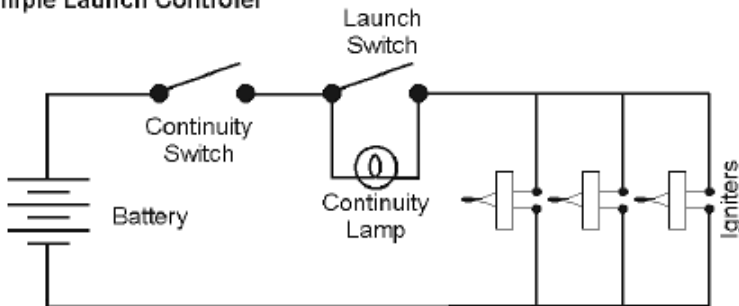

**Use PARALLEL circuit ONLY!**

**Taking extra care in igniter installation and hook up will save you countless hours of frustration with cluster models!**

© 2004, FlisKits, Inc., All rights reserved - Kevlar® is a registered trademark of Dupont

## ENGINEERING DIRECTIVE

<b>FROM:</b>	Office of Chief Engineer
<b>VEHICLE(S):</b>	CL004
<b>EFFECTIVE DATE:</b>	29-November-2004
Chief Ordnance Engineer <i>James M Flis</i>	Chief Deployment Engineer <i>Brian McCarthy</i>
Effective immediately, the attached procedures will be used in the assembly and deployment of Launch Vehicle CL004, known as "PayLord".	

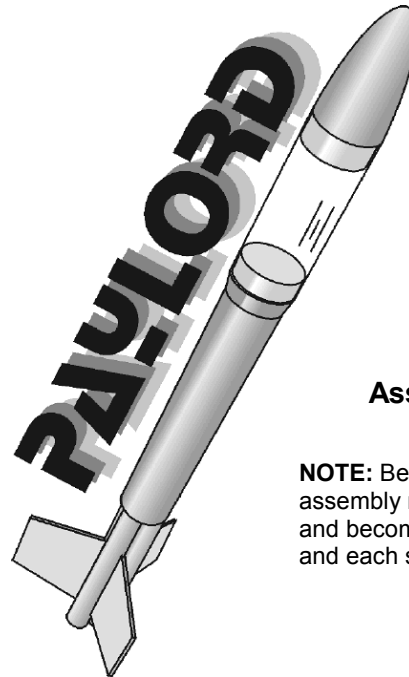

Recommended Motors:  
A8-3, B6-4, C6-5  
(3 matching motors required)  
Flying Model Rocket

### Assembly Instructions

**NOTE:** Before starting this assembly read all of the instructions and become familiar with each part and each step of the assembly.

In addition to the material supplied with this kit, you will need the following: Pencil, Hobby Knife, Ruler, fine Sand Paper, White Glue and Cyanoacrylate adhesive (super glue). For finishing, you will require: Sanding Sealer, Paint Brush, Masking Tape, Sand Paper, Primer paint and other paints of your choice.

In order to successfully fly you're **PayLord** model rocket, you will need the following: Recommended model rocket motors with igniters, a suitable Launch Pad with 3/16" Launch Rod and a Launch Controller with a 12VDC power source.

Welcome to the world of payload and cluster model rocketry! The **PayLord** model rocket kit comes with a large 9.26 cubic inch clear payload compartment that you can use to carry your payloads to great altitudes available through the use of a cluster motor mount.

Payloads can include raw hens eggs, camera's, electronic devices and a host of other interesting and exciting experiments. **NOTE:** FlisKits does not condone the use of live payloads.

Use your imagination! Great for experimenting and for science fair projects too!

1. Make a mark on an expended motor casing  $\frac{1}{4}$ " from one end. Apply a bead of glue about 1" inside one end of a **BT-20 Body Tube** and use the motor casing to push an **Engine Block** into the end of the tube up to the mark made on the motor casing. As shown in **Figure 1**. **REMOVE THE CASING QUICKLY** so that it does not become glued into the tube. Repeat this step with the remaining two tubes and Engine Blocks.

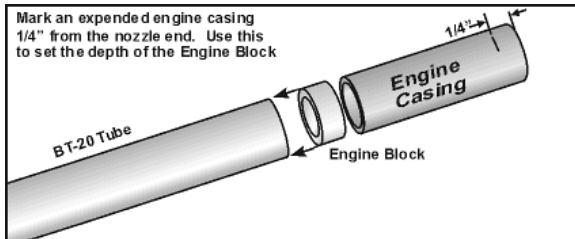

Figure 1

2. Referring to **Figure 2**, run a bead of glue along the full length of one BT-20 Body Tube. Take a second tube and, with both tubes laying on a smooth, flat surface, glue them together. **NOTE:** Make sure that the ends are flush with each other and that the Engine Blocks are at the same end.

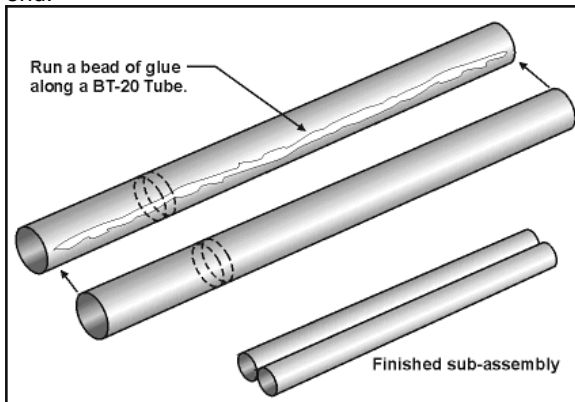

Figure 2

3. Attach the remaining BT-20 tube by placing a bead of glue on the two tubes from Step 2 as shown in **Figure 3**. As with Step 2, verify that the tube ends are flush and that the Engine Blocks are all at the same end. The end with the Engine Blocks is the "Rear" or "Bottom" of this assembly.

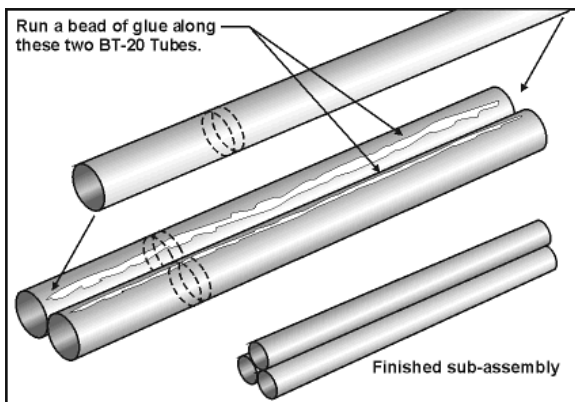

Figure 3

4. Referring to **Figure 4**, make one mark on EACH Engine Tube,  $\frac{3}{8}$ " from the bottom (**NOTE:** Make these marks in the crevice between tubes, as shown). Make a second mark on each Engine Tube  $5\frac{3}{4}$ " from the bottom, as shown.

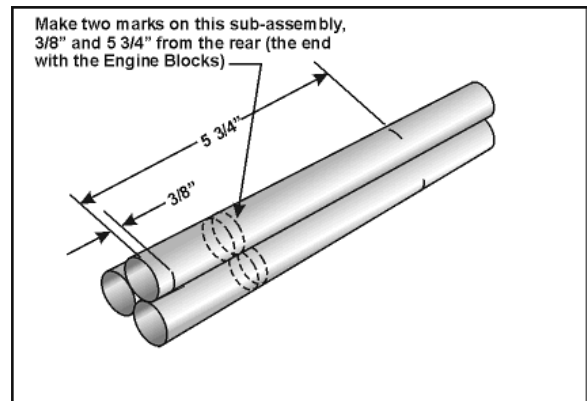

Figure 4

5. Locate the 3 **Vent Plugs** provided with this kit. One at a time, apply a bead of glue along the 2 inner curves of a Vent Plug and glue this to the Engine Tube assembly at the  $5\frac{3}{4}$ " mark, as shown in **Figure 5**. The 3 Vent Plugs should form a full circle around the assembly and be even (flush) with each other. When dry, apply a strong glue fillet on both sides of each Vent Plug.

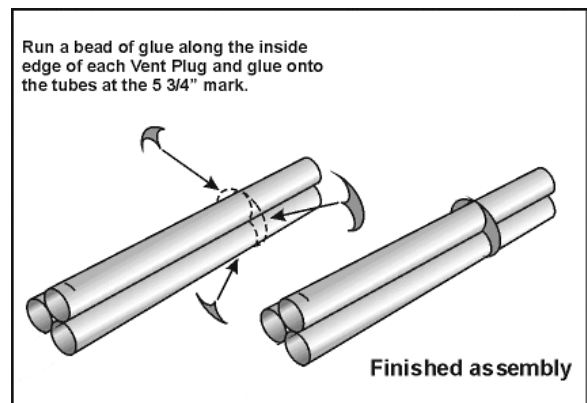

Figure 5

6. When the assembly from Step 5 is **COMPLETELY** dry, test fit this assembly into the BT-60 Main Body Tube. The tubes and Vent Plugs should slide easily into the Body Tube. If it is too tight, lightly sand the Vent Plugs until you get a smooth fit, then go on to Step 7.
7. Apply a bead of glue along each Engine Tube, between the Vent Plugs and the end of the assembly, as shown in **Figure 6**. Also apply a bead of glue just inside one end of the **BT-60 Main Body Tube**. Slide the Engine Tube Assembly into the Main Body Tube until the Vent Plugs are flush with the bottom of the BT-60.

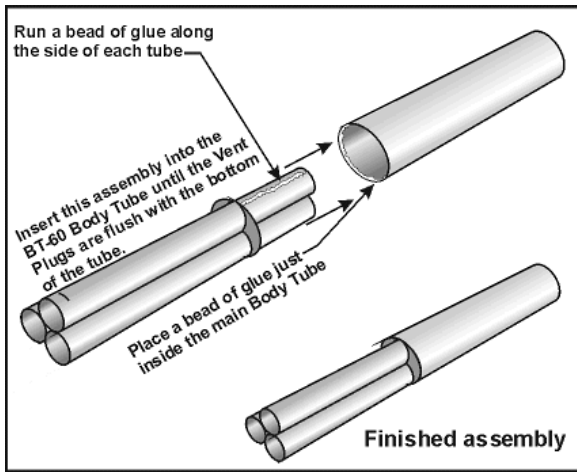

Figure 6

- Referring to **Figure 7**, draw a straight line the full length of the Main Body Tube. Locate this line such that it is centered where one of the Engine Tubes touches the Main Body Tube.

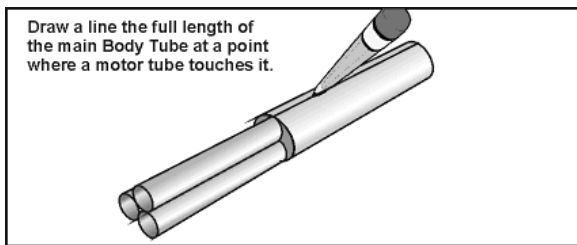

Figure 7

- Cut out the **Fin Pattern** and the **Launch Lug Standoff** pattern from the **Fin Pattern Sheet**. Use these patterns to cut out 3 **Fins** and 2 **Standoffs** from the provided Balsawood stock. Referring to **Figure 8**, sand a pointed taper to the **ROOT** edge of each fin. Sand the edges of the Standoff flat.

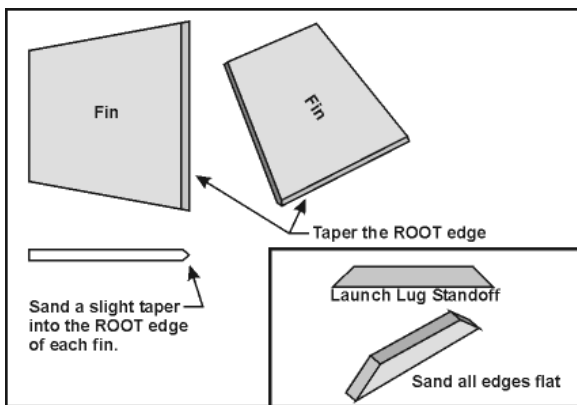

Figure 8

- Locate the **Launch Lug** provided with this kit. Glue it to the top (narrow part) of the Standoff, with the end of the lug near the edge of the standoff as shown in **Figure 9**. When dry, use your Razor Knife or Razor Saw to cut the Launch Lug at an angle that matches that of the Standoff. Glue the remainder of the Launch Lug to the second Standoff and trim in the same manner.

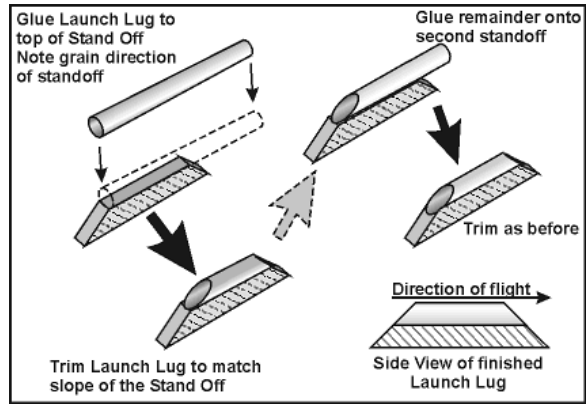

Figure 9

- Referring to **Figure 10**, run a 2" bead of glue in the notch between two Engine Tubes, beginning at the 3/8" mark made in Step 4. Place a knot in one end of the provided **Kevlar® cord** then lay this cord into the glue bead, with the knot at the 3/8" mark. Now, place a generous bead of glue along the entire Root edge of one fin and place this into the crevice, covering the cord and securing it in place. Make sure this fin is straight and dry before going on to the next step. (**NOTE:** The cord should be loose and free to move from the leading edge of the fin, forward)

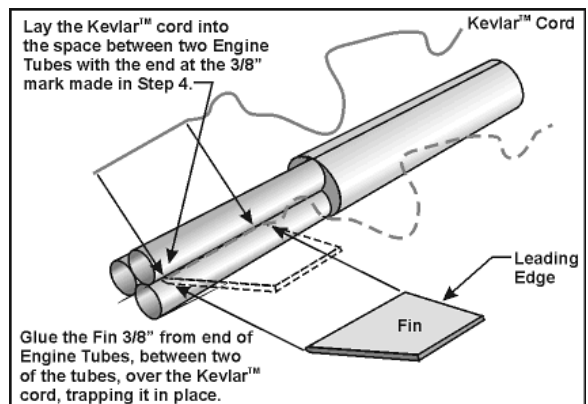

Figure 10

- Referring to **Figure 11** attach the remaining two fins in the same manner. The end view provided shows you the orientation of these fins, nested between the Engine Tubes.

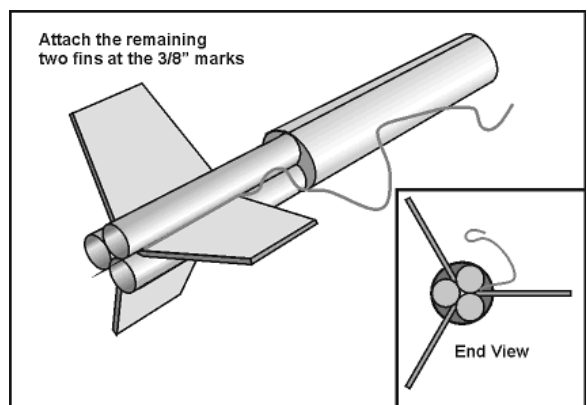
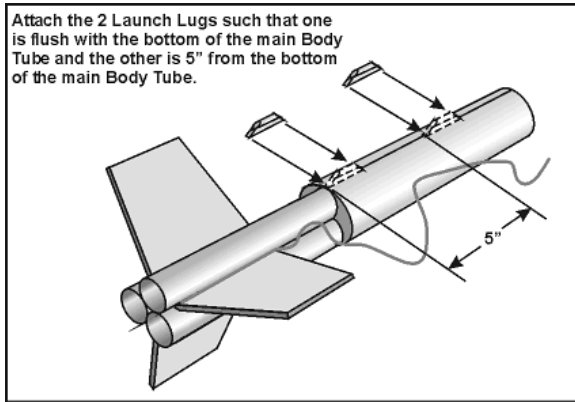

Figure 11

13. Apply a bead of glue along the underside of one Launch Lug Standoff and glue this to the Main Body Tube such that it is centered in the line made earlier and is flush with the bottom of the Main Body Tube, as shown in **Figure 12**. Glue the remaining Launch Lug Standoff to this same line, 5" from the bottom of the Main Body Tube. **NOTE:** Be sure that these two Launch Lugs are aligned with each other!



**Figure 12**

14. Locate the **Nose Cone**, **Payload Tube** and **Adapter**. Referring to **Figure 13**, slide the Nose Cone onto the Payload Tube and then slide the Adapter in place on the other end. These balsa parts should fit very snugly. **NOTE:** If they are loose, you can tighten them up with small pads of tape. Loose components could result in your payload section coming apart under the parachute causing you to lose your payload.

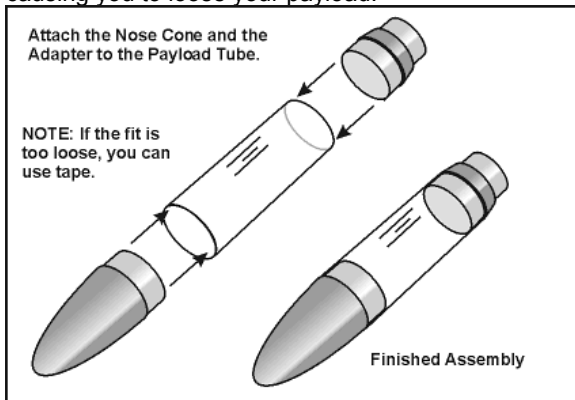

**Figure 13**

15. Take the **Screw Eye** and screw it into the base of the Adapter as shown in **Figure 14**. Remove the Screw Eye, apply a drop of glue into the hole and re-insert the Screw Eye.

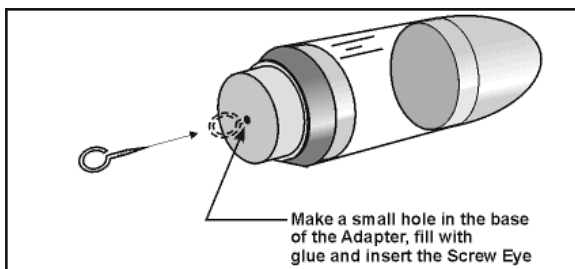

**Figure 14**

16. Tie one end of the elastic **Shock Cord** to the free end of the Kevlar line, then tie the other end to the Screw Eye in the Adapter. Assemble the **Parachute** per the instructions found on the parachute material and then tie the shroud lines of the Parachute to the Screw Eye also, as shown in **Figure 15**.

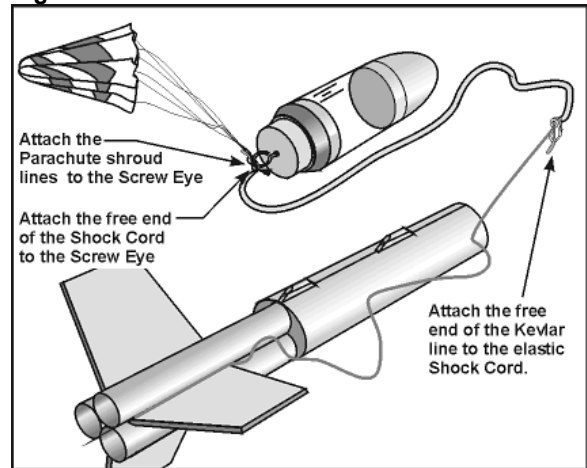

**Figure 15**

17. Referring to **Figure 16**, apply **strong** glue fillets to all tube/tube and fin/tube joints. Cluster rockets are subjected to greater stress than most other model rockets and strong glue joints are critical.

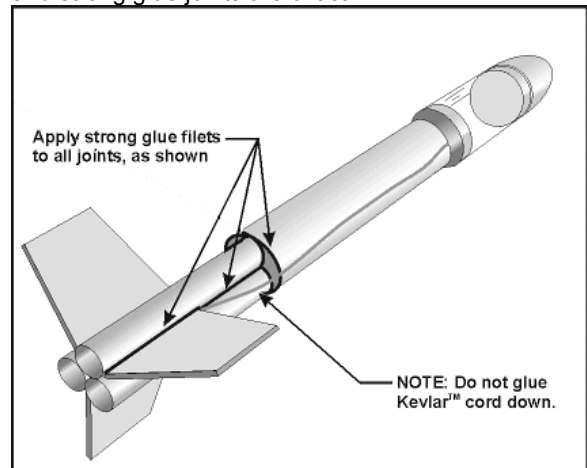

**Figure 16**

Congratulations! You have completed the assembly of the **PayLord model rocket kit from FlisKits**. This fine model will be the workhorse of your fleet! Be sure to tell your friends where you got it!

To finish your model, seal all balsa parts with 2-3 coats of sanding sealer, sanding between coats with 400 grit sand paper. **NOTE:** Remove the Payload tube first to protect it from the sealer and sandpaper! Paint the model in your choice of colors. You can use the kit cover art for painting ideas. The original PayLord model was painted in a red, white and blue motif. Try to keep the Kevlar® cord free from paint so that it remains flexible.

Go to the left side of the first page for tips on cluster launch techniques.